

# RING STAR

## Accessories & Ordering Info



### Ring Star lubrication gun

Description	Part number
Manual, compressed air operated lubrication gun for safe application of lubricant in rotary kilns	J2E5A7



### Ring Star automatic application unit

Description	Part number
Automatic lubricant application unit operated with compressed air	J9M3A5



### Compressed air filter regulator

Description	Part number
0,3-7 bar, 40 µm with coupling G 1/4" connection	T9F5A6



## Filling pump for 60L/200L drums

Flow rate	Tank	Hose length	Part number
Adjustable 0,10 - 0,15 - 0,20 - 0,25 dm <sup>3</sup> /Hub	Applicable for 60 and 200L drum	1,5m	X9U4A2



## Filling pump with tank

Flow rate	Tank	Hose length	Part number
0,12 dm <sup>3</sup> /Hub	16 dm <sup>3</sup>	1,5m	U9U4A5

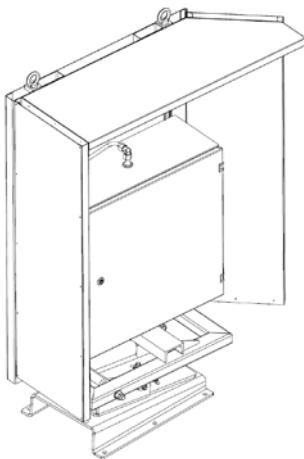

## Swivel device and heat protection

System for fine adjustment of the application process

Description	Part number
left version	V2T4A6
right version	C3T4A0



## Protective cabinet for Ring Star lubrication gun

Description	Part number
On-site protection cabinet for manual lubrication gun	L9L3A4



## Straight extension for Ring Star lubrication gun

Description	Part number
1m length, to extend the firing distance	Y8G5A3



## 45° extension for Ring Star lubrication gun

Description	Part number
1m length, to extend the firing distance	M1J5A3



## Monopod for Ring Star lubrication gun

Description	Part number
For easier handling	C1J5A2



For detailed information about our Ring Star Lubrication system, please have a look at our brochure: [www.sslubac.com/en/download-area](http://www.sslubac.com/en/download-area)

For **orders or queries**, please contact us at:

T: +43 6132 23 741 or [office@sslubac.com](mailto:office@sslubac.com)